

**KES** (runder Deckel)  
**3.00/1.50/2.00** (ohne Einmündungstrichter)  
**Schalung**

**NZ\_B\_032**

Massstab : 1:50 / 1:20	Datum : Sept. 2010
Bearbeitet : EM	Gesehen : CR

 LIEFERUNG  
BAUSEITS

**zulässige Belastung:**  
ca. 40cm überdeckt  
Radlast 150 kN

**Längsschnitt 1:50**

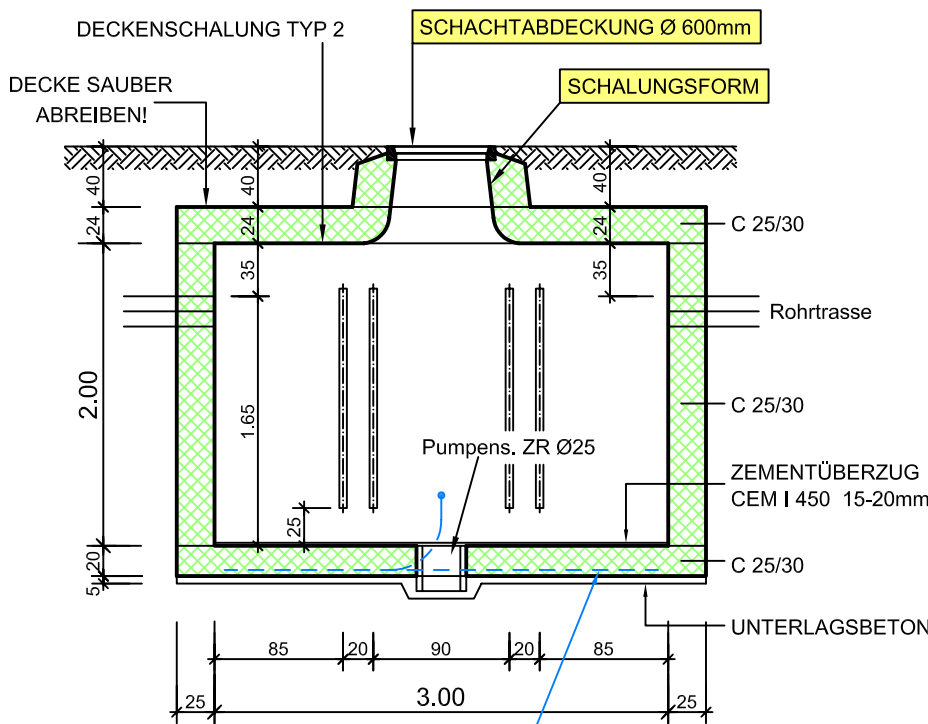

Einlage Erdungsseil gem. Plan NZ\_B\_043

**Querschnitt 1:50**

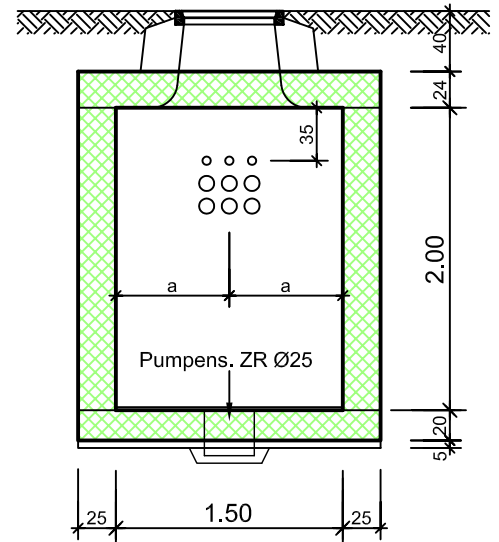

**Grundriss 1:50**

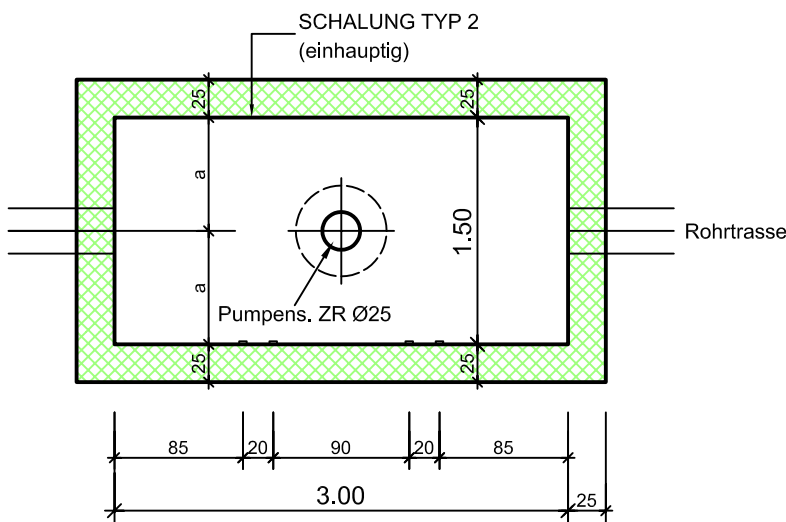

**Schnittdetail 1:20**

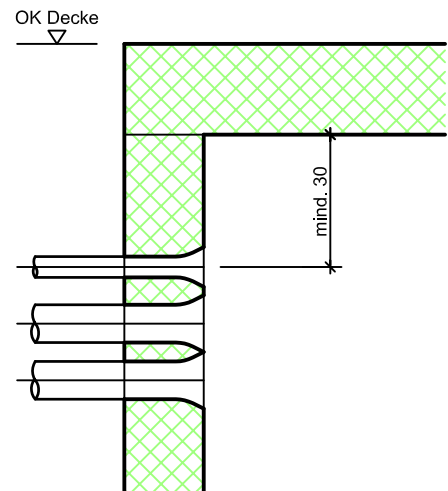

**KES** (runder Deckel)  
 3.00/1.50/2.00 (ohne Einmündungstrichter)  
 Armierung

**NZ\_B\_032**

Massstab : 1:50 / 1:25	Datum : Sept. 2010
Bearbeitet : EM	Gesehen : CR

**Grundriss 1:50**  
 Armierung Boden

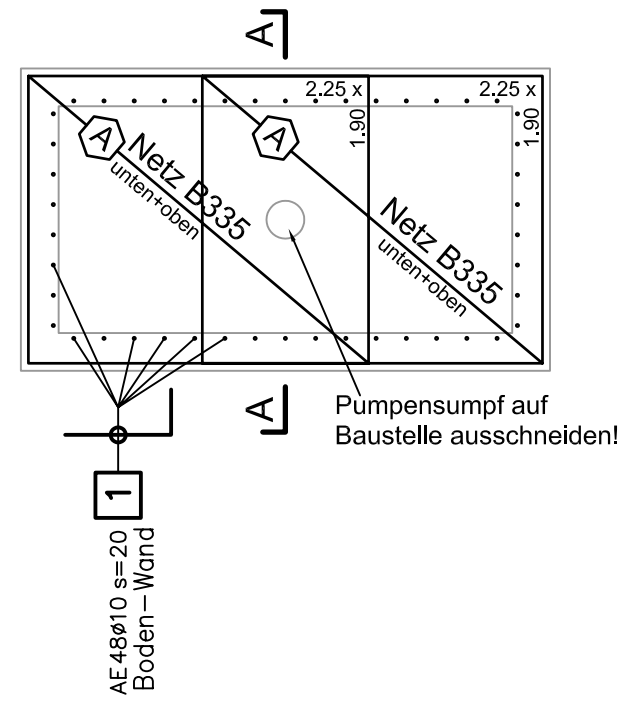

**Grundriss 1:50**  
 Armierung Wände

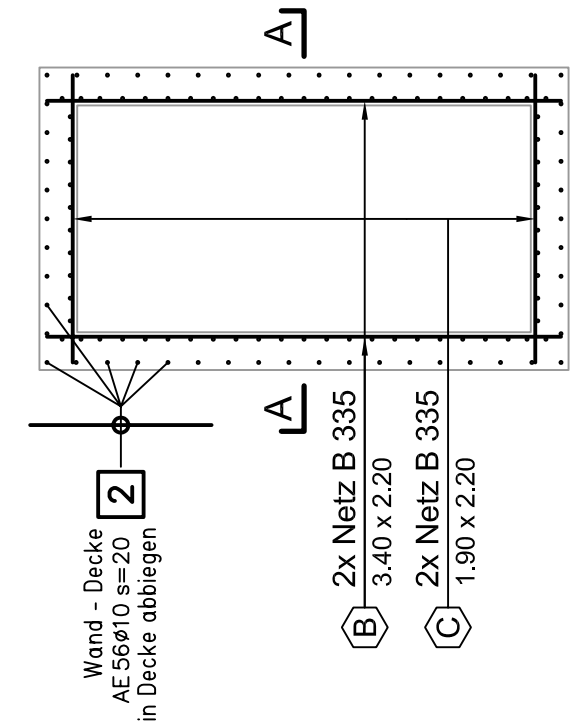

**Grundriss 1:25**  
 Armierung Decke

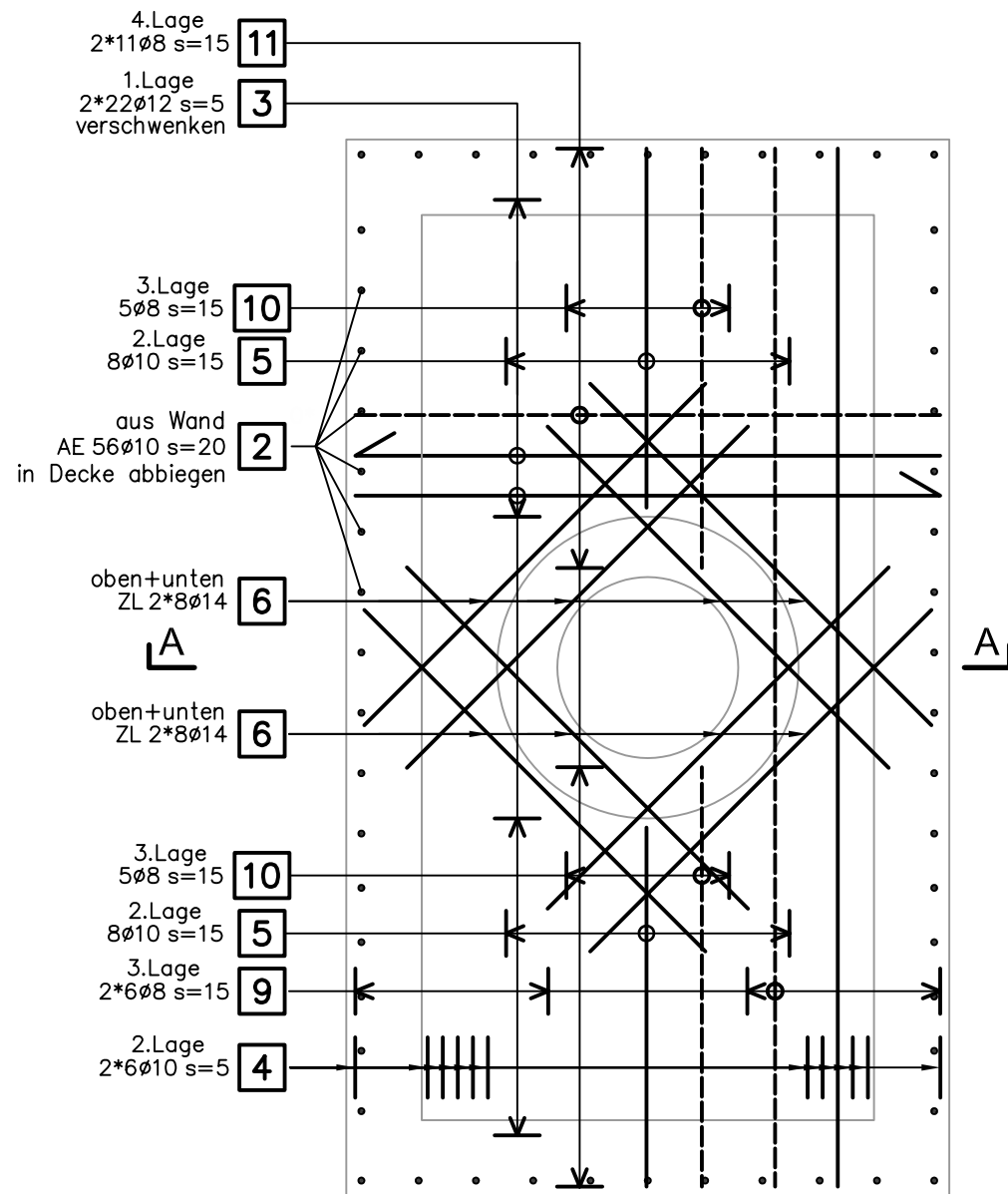

3cm Eisenüberdeckung

Lagerlängen 12 1ø8

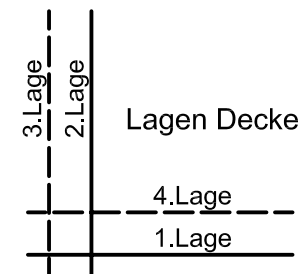

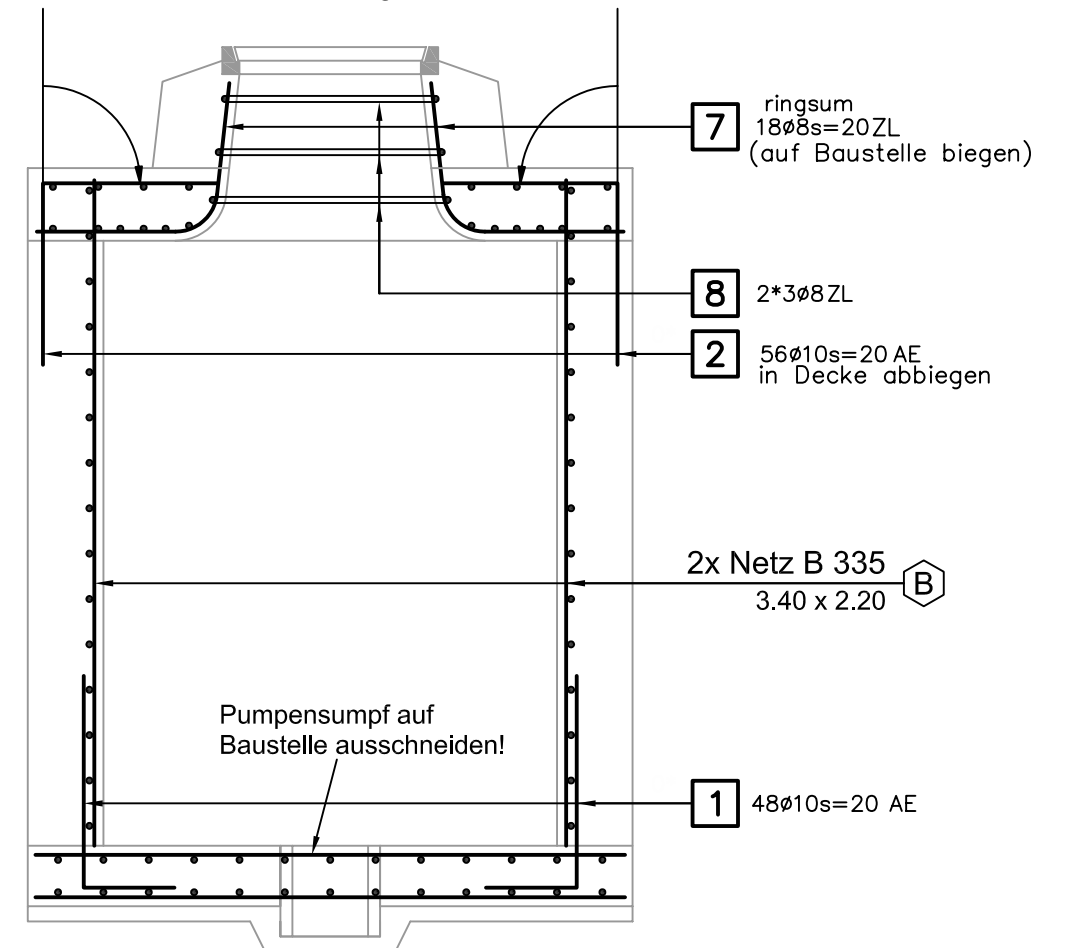

**Schnitt A - A 1:25**  
 Armierung



<b>BAUOBJEKT</b>	<b>Liechtensteinische Kraftwerke</b> Im alten Riet 17, FL-9494 Schaan Tel. +423 236 01 11, Fax +423 236 01 12 lkW@lkW.li, www.lkW.li		BETONSTAHLLISTE NR. <b>NZ_B_032_EL</b>						
	<b>KES</b> <b>3.00/1.50/2.00</b>	ZU PLAN NR. <b>NZ_B_032</b>							
<b>BAUUNT.</b>			<table border="1" style="width: 100%; border-collapse: collapse;"> <tr> <td style="width: 30%;">Datum</td> <td style="width: 40%;">Sept. 2010</td> <td style="width: 30%;">Gepr.</td> </tr> <tr> <td>Gez.</td> <td>EM</td> <td>Rev.</td> </tr> </table>	Datum	Sept. 2010	Gepr.	Gez.	EM	Rev.
	Datum	Sept. 2010	Gepr.						
Gez.	EM	Rev.							
		<b>BETONSTAHL</b> <b>GEMÄSS SIA-NORM 262</b> <b>ERGÄNZUNG 262/1</b>							
<b>INGENIEUR</b>	<b>Wenaweser+Partner</b> Bauingenieure AG		Büro Schaan, Schmedgässle 2, FL-9494 Schaan Tel: +423 237 50 80 / Fax: +423 237 50 81						
	info@bauingenieure.li www.bauingenieure.li		Büro Ruggell, Noflerstrasse 12, FL-9491 Ruggell Tel: +423 370 18 90 / Fax: +423 370 18 94						

ZUSAMMENFASSUNG B500B							
Anzahl Pos.	Fix- und Lagerlängen		Meter-Gewicht kg/m	Durchmesser mm	Anzahl Pos.	Bearbeitet	
	Länge m	Gewicht kg				Länge m	Gewicht kg
5	145.86	57.615	0.395	8	1	9.78	3.863
3	127.52	78.680	0.617	10	1	48.00	29.616
1	51.20	61.952	0.888	12	1	91.96	81.660
9	Gesamt	198.247			3	Gesamt	115.140
<b>GESAMTMENGE</b>							<b>313.386</b>

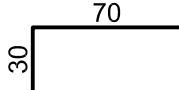
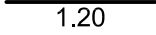
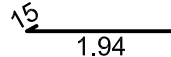
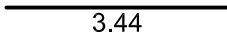
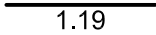
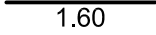
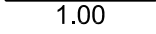
Abstandhalter				Stützbügel	
Typ	Stückzahl	Länge Total m	Höhe cm	Stückzahl	Höhe cm
DISTANZKORB-H90MM-OHNE-FUSS	4	10.00	9.0		

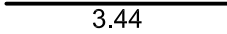
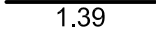
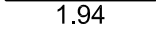
Pos.	Stk.	d	Länge	Ges.L	Gewicht kg	Biegeform
1	48	10	1.00	48.00	29.616	
2	56	10	1.20	67.20	41.462	
3	44	12	2.09	91.96	81.660	
4	12	10	3.44	41.28	25.470	
5	16	10	1.19	19.04	11.748	
6	32	14	1.60	51.20	61.952	
7	18	8	1.00	18.00	7.110	
8	6	8	1.63	9.78	3.863	 <div style="display: inline-block; vertical-align: middle; margin-left: 20px;"> <math>\frac{l}{1.63} &gt; \frac{275}{8} \frac{r}{0.34}</math> </div>
9	12	8	3.44	41.28	16.306	
10	10	8	1.39	13.90	5.491	
11	22	8	1.94	42.68	16.859	
12	lfdm	8	30	30.00	11.850	

# NETZLISTE

Objekt: **Liechtensteinische Kraftwerke**  
 Im alten Riet 17, FL-9494 Schaan  
 Tel. +423 236 01 11, Fax +423 236 01 12  
 lk@lkw.li, www.lkw.li



Bauteil: **KES 3.00/1.50/2.00**  
 Ingenieur: **Wenaweser + Partner AG**  
**Schmedgässle 2**  
**FL-9494 Schaan**

Trennplan Nr.: **NZ\_B\_032\_NL**

zu Verlegeplan Nr.: **NZ\_B\_032**

Datum: **Sept. 2010** gez: **EM** kontr.:

Unternehmer:

Liefertermin:

Bemerkung: Lieferung mit Kranwagen  ja  nein

Typ **B 335.39**  
2 Stück

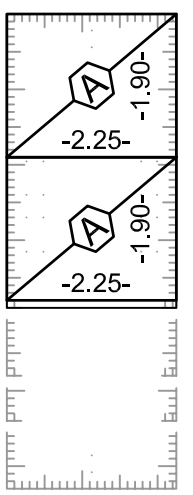

Typ **B 335.54**  
2 Stück

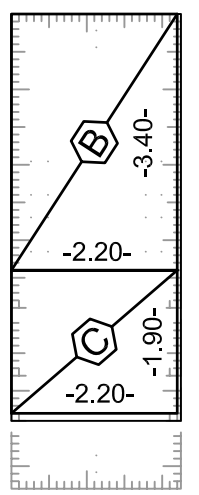

Typ .....  
..... Stück

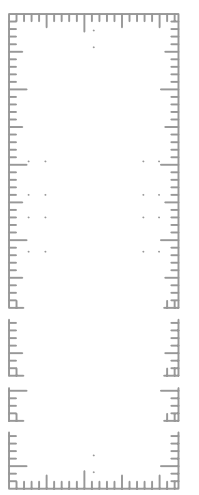

Typ .....  
..... Stück

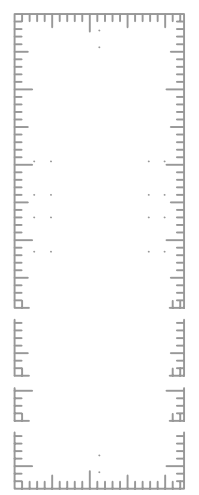

**Lagermatten**

nach Trennplan bearbeitet  
 unbearbeitet

Typ	Stück	Gewicht kg
B 335.39	2	93.8
B 335.54	2	129.8
Total Gewicht kg		223.6
Anzahl Mattenpos.		3

Typ .....  
..... Stück

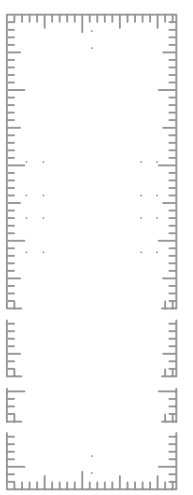

Typ .....  
..... Stück

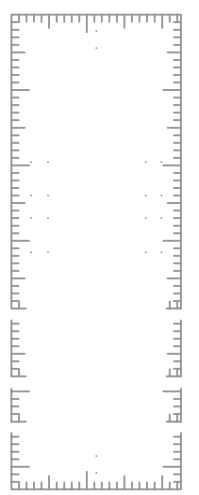

Typ .....  
..... Stück

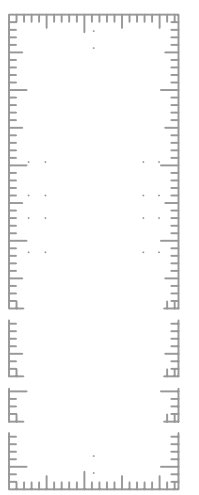

Typ .....  
..... Stück

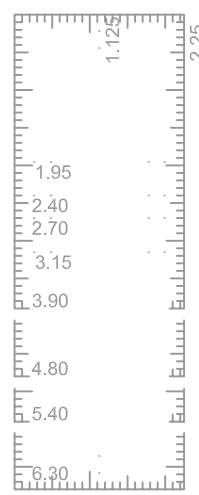

**Distanzkörbe**

mit oder ohne Kunststoff-Fuss  
 Länge 2.50m Bunde à 10Stück

Höhe mm	Stück	m	mit	ohne
			<input type="checkbox"/>	<input type="checkbox"/>
			<input type="checkbox"/>	<input type="checkbox"/>
			<input type="checkbox"/>	<input type="checkbox"/>
			<input type="checkbox"/>	<input type="checkbox"/>

**Anschlusskörbe AU forwa®**

Länge 3.04m

Typ	Stück	m

**Anschlusskörbe FIRIPA®**

Länge 3.00m

Typ	Stück	m